



“Creating Vacuum, Relieving Pressure”



Meet the New Addition to Fruitland Manufacturing’s Eliminator Series!

The “*Ready2Rig*” MK250

This Heavy Duty yet conveniently compact Rotary Vane Vacuum Pump System is outfitted with all the high standard design features that you have come to expect from Fruitland.



- *Includes RCF250 Vacuum Pump
- *Vacuum/ Pressure Relief Valves
- *Integrated Durable Secondary Shutoff
- *Powder Coated Components
- *High Efficiency Oil Catch Muffler
- *Gearbox or Hydraulic Drive Option
- *Heavy Duty Rugged Pump Stand
- *180 CFM Vacuum Pump
- *Compact and Durable
- *2 Year Warranty

The Perfect Fit for your Portable Sanitation Service Truck!

Contact Fruitland Manufacturing Toll Free 1-800-663-9003 Phone 905-662-6552 or
www.fruitlandmanufacturing.com



The “*Ready2Rig*” MK250

Design Features that lower your operating costs!

- *Every Pump Factory Tested
- *2 Year Factory Warranty
- *Proven in Challenging Environments
- *Automatic Oiling System/Steel Lines
- *No Temperature Gauges to Monitor
- *Low Oil Consumption
- *Fan Cooled
- *Low Maintenance
- *Vane Wear Gauging Ports
- *Worldwide Distribution

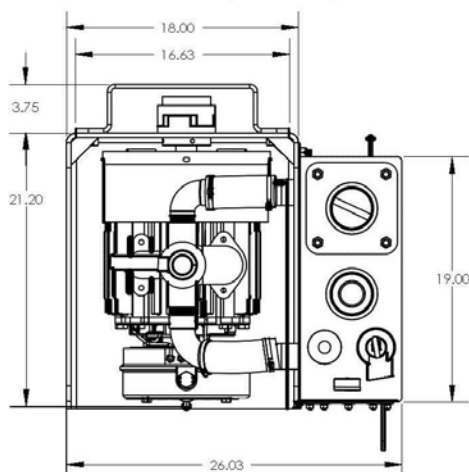
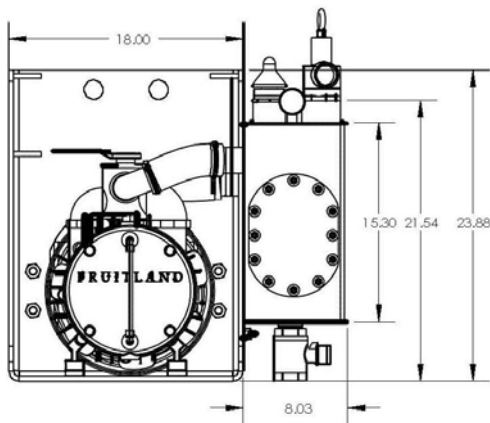

CFM at Free Air	180 CFM
Maximum Vacuum	27" H
Size of Connecting Hoses	3"
Maximum Operating Speed	1400 RPM
Vanes	4 (Fibre)
Approx. net Weight	385LBS

Installation as Easy as 1,2,3!

- 1. Bolt it up.**
- 2. Connect Drive and Plumbing.**
- 3. Begin Loading and Unloading.**

The Perfect Fit for your Portable Sanitation Service Truck!

Contact Fruitland Manufacturing Toll Free 1-800-663-9003 Phone 905-662-6552
www.fruitlandmanufacturing.com

