

CHANGES

REV.	DATE	ERN	DESCRIPTION	BY
A1	10/29/99	None	Released for production	JWD

- 1) NPV4-17 Handle fastener kit
 1) NPV4-17/1 5/16"x1-3/8" clevis pin
 2) NPV4-17/2 3/8"x1-1/8" clevis pin
 3) NPV4-17/3 1/8"x1" cotter pins

Packing nut:
 NPV4-06B for NPV6C ass'y
 NPV4-06S for NPV6S ass'y

3) NPV4-08A
 Packing 1.0" ODx.625"IDx3/16" Acrylic/PTFE

NPV4-09V Viton rubber washer
 1.03" OD x .62" ID x .125"

6) NPV6-11B 1/2-13x1.25 SHCS, 18-8 st/stl w/
 6) NPV6-11W 1/2" lock washers, 18-8 st/stl

Bonnet, NPV6-02C carbon stl
 Option: NPV6-02S (316 st/stl)

Stem, NPV6-07S

Bonnet gasket, NPV6-12

NPV6-03S-1A, Fixed gate
 NPV6-03S-1B, Floating gate

Body, NPV6-01C (carbon stl)
 Option: NPV6-01S (316 st/stl)

2) NPV6-13V O-ring
 2-258 (6"ID x 1/8"W)

2) NPV6-14V, O-ring
 2-261 (6-3/4"ID x 1/8"W)

2) NPV6-05S, Seat

Flanged bearing:
 NPV4-10B for NPV6C ass'y
 2) NPV4-10T for NPV6S ass'y

Packing nut:
 NPV4-06S

Flanged bearing:
 2) NPV4-10T

NPV6S

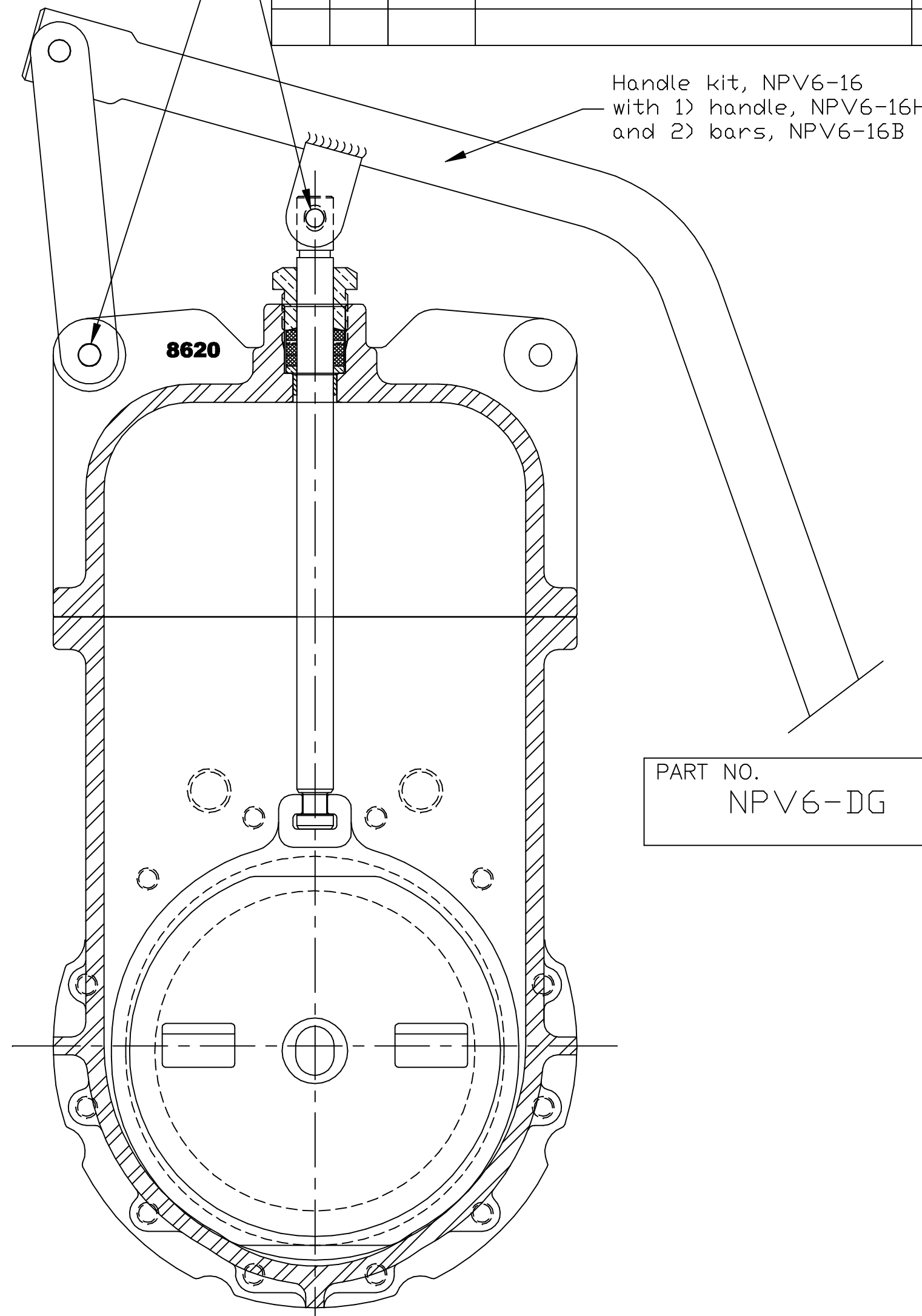

Handle kit, NPV6-16
 with 1) handle, NPV6-16H
 and 2) bars, NPV6-16B

PART NO.
 NPV6-DG

6" Gate Valve

Assembly part numbers:

NPV6C-DG - 8620 Carbon steel body (NPV6-01C) and bonnet (NPV6-02C).

NPV6S-DG - 316 Stainlesssteel body (NPV6-01S) and bonnet (NPV6-02S).

TOLERANCES UNLESS OTHERWISE SPECIFIED

One place (.X)	±.1
Two place (.XX)	±.03
Three place (.XXX)	±.015
Angles	±1°

All machined surfaces 125 RMS max.
 Remove all burrs and sharp edges.
 CAD drawing - NO manual changes.

This document may contain confidential trade secret information which is the exclusive property of National Vacuum Equipment. Any information on this drawing is not to be disclosed to anyone not having a "Need to Know." The information contained herein is to be used only in accordance with the best interests of National Vacuum Equipment.

NVE National Vacuum Equipment, Inc.
 2670 Aero Park Drive, Traverse City, MI 49686
 Phone (616) 941-0215 Fax (616) 941-2354

PART NAME:
 6" Dual gate valve

MATERIAL: See part number

DRAWN BY: JWD CHECKED BY: JWD

SCALE: 1=1 DATE 1/22/02

SHEET: 1 of 1 PART NO. NPV6-DG